

# NIBE air source heat pumps from Nu-Heat



Air source heat pumps designed to provide an efficient, low-carbon solution for space heating and domestic hot water.

## NIBE air source heat pump range

Swedish company, NIBE, has been manufacturing heat pumps globally for 40 years. Their industry-leading air source heat pumps not only look great, they also offer the highest levels of performance and functionality.

## NIBE ASHP range features

- ✓ Incredibly quiet thanks to Owl Wing fan design, producing maximum sound power levels as low as 50 decibels
- ✓ Intuitive control with smart connectivity
- ✓ Compact units available in four sizes: 6kW, 8kW, 12kW and 16kW
- ✓ Cascade and hybrid options to suit a wide range of properties
- ✓ MCS approved for Renewable Heat Incentive applications
- ✓ 7-year warranty when commissioned by a Nu-Heat engineer
- ✓ Pair with our EnergyPro® cylinders for domestic hot water

## Smart connectivity with NIBE Uplink™ and myUplink™

When connected to the internet, NIBE Uplink™ and new, smart myUplink™, provides a quick and simple way to monitor and control the heat pump and feedback on system performance.

It's intuitive to use, meaning that you can optimise the air source heat pump's energy consumption, keep an eye on running costs and create the perfect level of comfort in the home.

## Why choose a heat pump from Nu-Heat?

As a MCS accredited company, we know what it takes to design an efficient system that effectively heats a home, whilst also keeping running costs low.

Our systems include tailored project schematics and all system components and fittings as standard, for a quick and smooth installation that is backed up with lifetime technical support.



### Bespoke heating design

Seamlessly integrating the air source heat pump and underfloor heating



### Long 7-year warranty

Benefit from a 7-year warranty when commissioned by a Nu-Heat engineer



### Supporting RHI applications

Access the RHI with our MCS support package which includes on-site commissioning



### Free lifetime support

We support Nu-Heat systems for life, so you can always call on us for technical support



### Award-winning customer service

Proud to hold a Distinction from the Institute of Customer Service

## Typical system schematic

- 1 NIBE F2040 air source heat pump
- 2 SMOS40 or SMO20 controller
- 3 EnergyPro® HP cylinder
- 4 Buffer tank
- 5 Domestic hot water out
- 6 Balanced cold out
- 7 Mains cold in
- 8 Heating flow and return

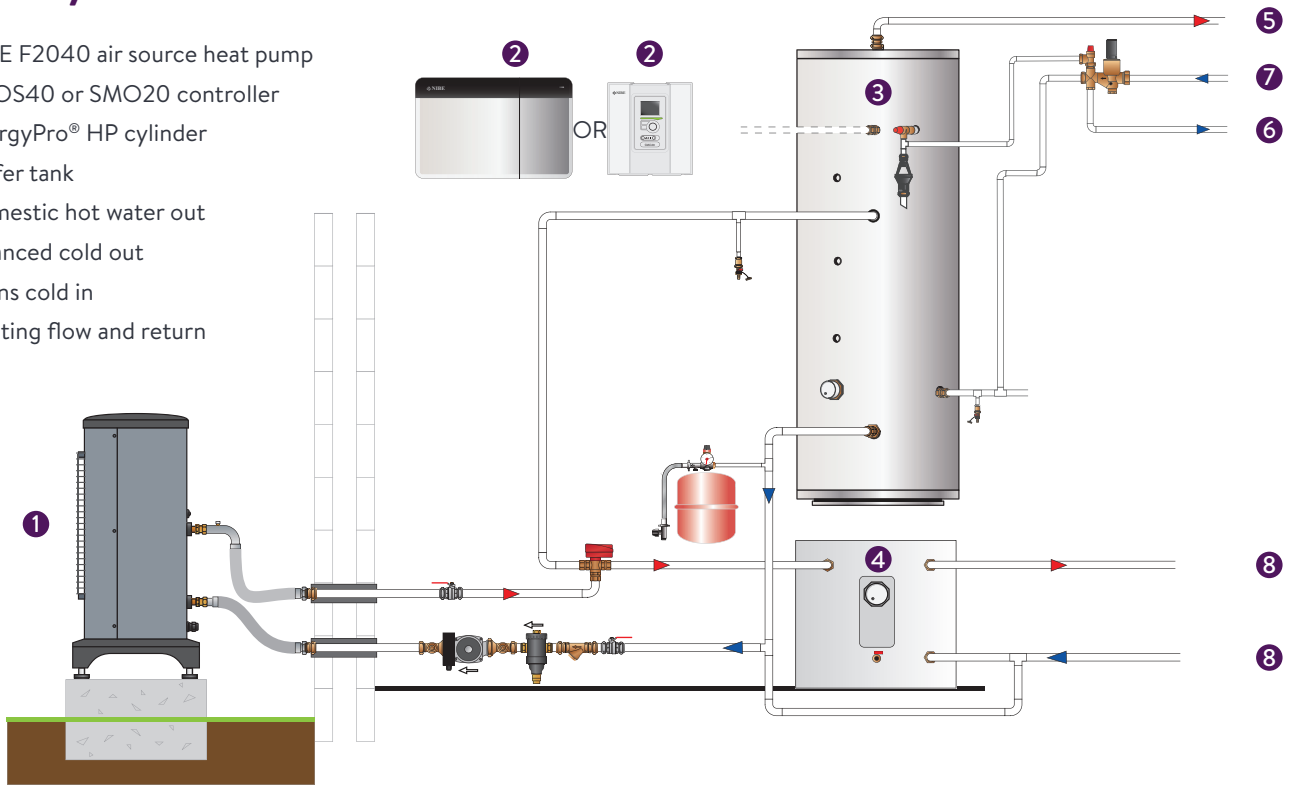

## Which unit will I need?

We will take factors such as the size of the property, location and domestic hot water demand into account to select the right size heat pump for the project.

## Technical specification

Model	F2040-6	F2040-8	F2040-12	F2040-16
CoP at 7/35°C*	3.5	4.3	4.5	4.53
Power output at 7/35°C (kW)	7.0	9.2	12.5	16.9
Operating voltage	230V 50Hz			
Max. outgoing heating medium temp.	58°C			
Height with stand (mm)	791	945	1045	1500
Width (mm)	993	1035	1145	
Depth (mm)	364	422	452s	
Weight (kg)	66	90	105	135
Sound pressure level at 2m free standing* (dB(A))	36	40	43	47
Sound pressure level at 6m free standing* (dB(A))	26.5	30.5	33.5	37.5
Sound pressure level at 10m free standing* (dB(A))	22	26	29	33
Max sound power level (dB(A))***	50	54	57	61

\* In accordance with EN 14511 for heat source entry at 7°C / hot water flow at 35°C.

\*\* Free space

\*\*\* In accordance with EN-12102

## Positioning the unit

NIBE air source heat pumps can be installed on almost any kind of terrain and are supplied in a range of sizes to suit small, medium or large homes and even light commercial buildings.

- Place F2040 outdoors on a solid level base, preferably a concrete foundation; do not place it directly on a lawn or other non-solid surface. If used, concrete slabs must rest on tarmac or gravel.
- The foundation should be positioned so that the lower edge of the evaporator is at a minimum of 300mm above ground level. Areas that are prone to standing water or heavy snow should take this into consideration when selecting the appropriate height above ground level.
- The F2040 should not be positioned next to a habitable room or to inconvenience neighbours. We can help calculate this to meet MCS020
- Condensation water should be directed to a drain or similar.
- Positioning should be in accordance with local planning guidance.

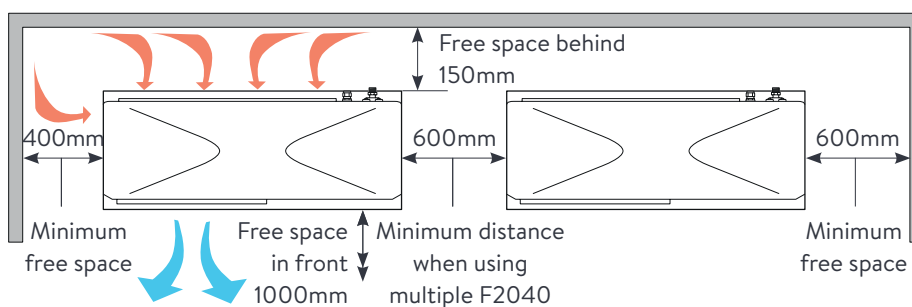
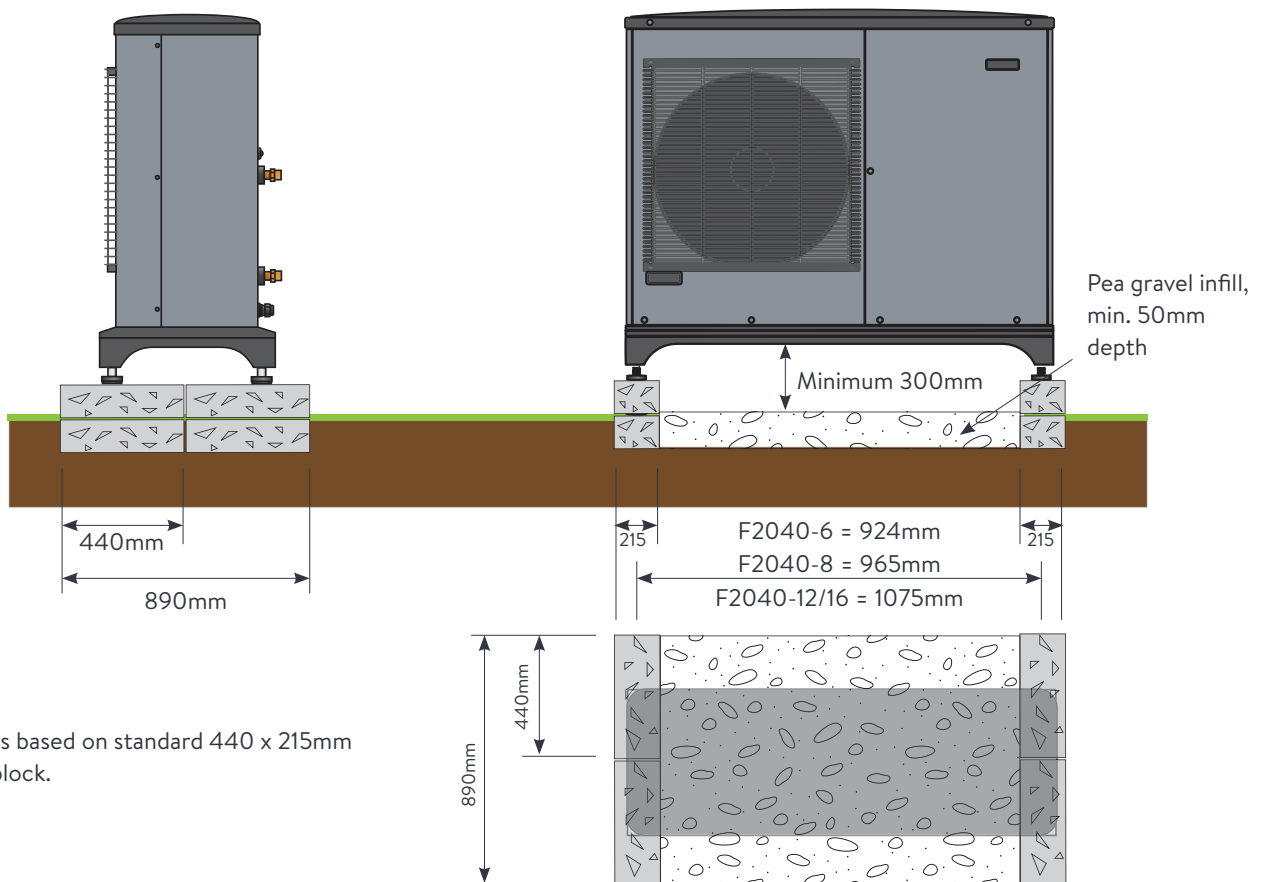

## Distance from the property

For a heat pump using 32mm (DN25) insulated plastic pipe connections between the heat pump and property the maximum distance permitted is shown in the table. This will be checked at the design stage. If your project falls outside these criteria please speak to your Project Engineer.

For full details please refer to the NIBE F2040 Installation Manual available at [www.nibe.co.uk](http://www.nibe.co.uk).

Heat Pump	Max Distance
F2040-6	99m
F2040-8	99m
F2040-12	79m
F2040-16	23m

## Energy efficiency fiche

Model	F2040-6		F2040-8		F2040-12		F2040-16	
Temperature application (°C)	35	55	35	55	35	55	35	55
Seasonal space heating energy efficiency class, average climate	A++							
Rated heat output, average climate (kW)	5		8.2	7	11.5	10	14.5	14
Annual energy consumption for space heating, average climate (kWh)	2089	3091	3882	4447	5382	6136	6702	8431
Seasonal space heating energy efficiency, average climate (%)	188	138	172	127	174	132	176	134
Sound power level LWA indoors (dB)	35							
Rated heat output, cold climate (kW)	4	6	9	10	11.5	13	15	16
Rated heat output, warm climate (kW)	4	5	8	8	12	12	15	15
Annual energy consumption for space heating, cold climate (kWh)	2694	4610	6264	8844	7798	11197	10040	13629
Annual energy consumption for space heating, warm climate (kWh)	872	1398	1879	2333	2759	3419	3370	4183
Seasonal space heating energy efficiency, cold climate (%)	143	116	139	108	142	111	144	113
Seasonal space heating energy efficiency, warm climate (%)	252	179	225	180	229	185	235	189
Max sound power level LWA outdoors (dB(A))	50		54		57		61	